

# MARSH®

Marsh Shipping Supply Co., LLC.

**Hand Stencil Machine**

**Owner's Manual**

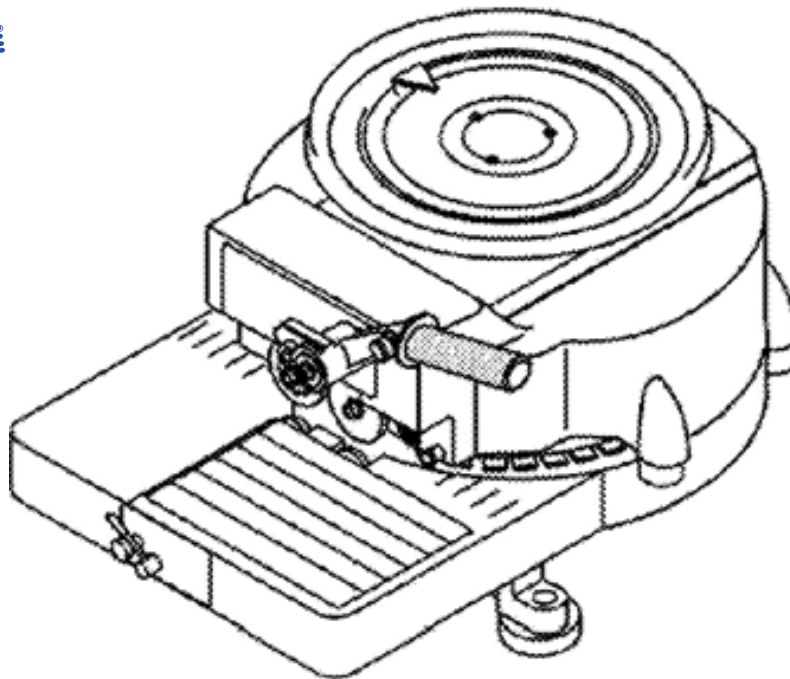

Distributed by:  
Pro Pack Solutions, Inc.  
2421B Lance Court  
Loganville, Georgia 30052  
Phone Toll Free: 877-776-7225 or 770-554-1187  
[www.ProPackSolutions.com](http://www.ProPackSolutions.com)

**Table of  
Contents**

Introduction .....3  
Installation .....4  
Operation .....5  
Maintenance .....7  
Troubleshooting .....9  
Repair .....11  
Parts List .....17

## Introduction

---

### **The Hand Stencil Machine Owner's Manual**

This Marsh Hand Stencil Machine Owner's Manual provides operation and maintenance instructions for all Q, H, S, and R models. Marsh Shipping Supply Company, LLC manufactures stencil machines that cut 1/4" (6.35 mm), 1/2" (12.7 mm), 3/4" (19.05 mm) and 1" (25.4 mm) characters. Your stencil machine will cut neat, precisely spaced characters in oilboard, which may then be inked with Marsh Fountain Rollers, Fountain Brushes, Spray Inks, K Stencil Inks, Rolmark and Poly Rolmark inks. Inked stencil boards can be used to mark on pipe, fiber cartons, or metal and wood containers. To order replacement parts, please refer to the Parts List (pg. 21) section in this manual.

For more assistance, or if you would like to obtain information about any Marsh product, please contact your Marsh distributor or Marsh Shipping Supply Company, LLC at

### **Marsh Shipping Supply Company, LLC**

Address: 926 McDonough Lake Road  
Collinsville, IL 62234  
USA

Telephone: 618.343.1006

Fax: 618.343.1016

Email: [tech@msscllc.com](mailto:tech@msscllc.com)

Distributed by:  
Pro Pack Solutions, Inc.  
2421B Lance Court  
Loganville, Georgia 30052  
Phone Toll Free: 877-776-7225 or 770-554-1187  
[www.ProPackSolutions.com](http://www.ProPackSolutions.com)

# Installation

---

## Introduction

Your stencil machine is fully assembled and packed safely in a shipping carton. No assembly is necessary after you unpack your machine.

Choose a location for the machine that is solid and about 30" (762 mm) high. The front of the bench or shelf should extend about 1" (25.4 mm) past the front of the machine so that it remains level and secure.

**Figure A**

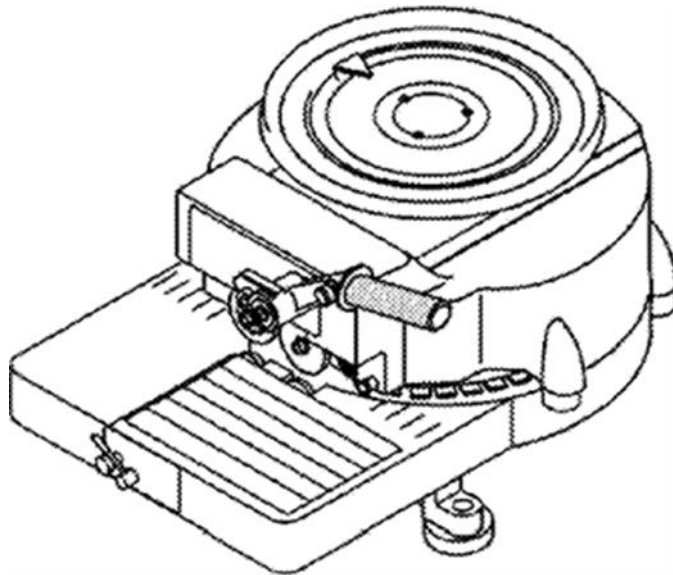

## Operation

---

### Inserting the Stencil Board

Natural oilboard, with a thickness of .015" (0.38 mm), is recommended for use with 1" (25.4 mm), 3/4" (19.05 mm), and 1/2" (12.7 mm) machines and for use with Marsh Fountain Roller, Fountain Brush or Spray Inks. Use Lightweight oilboard .011" (0.28 mm) with 1/4" (6.35 mm) machines. To insert the oilboard, refer to the following steps and Figure B.

1. Move the release lever to the right. This drops the lower feed roller assembly and allows space for the insertion of the oilboard.
2. Position the oilboard so that the top edge covers the punch center lines and then align the bottom edge of the oilboard with the appropriate guide line. See Figure B. The left edge of the oilboard may align with the left side of the guide line markings. If you need a wider left margin you may align the left edge of the oilboard with one of the punch center lines. See Figure B.
3. When the oilboard is in position, push the release button. The release lever snaps back to its original position and raises the lower feed rollers to secure the stencil board.

**Figure B**

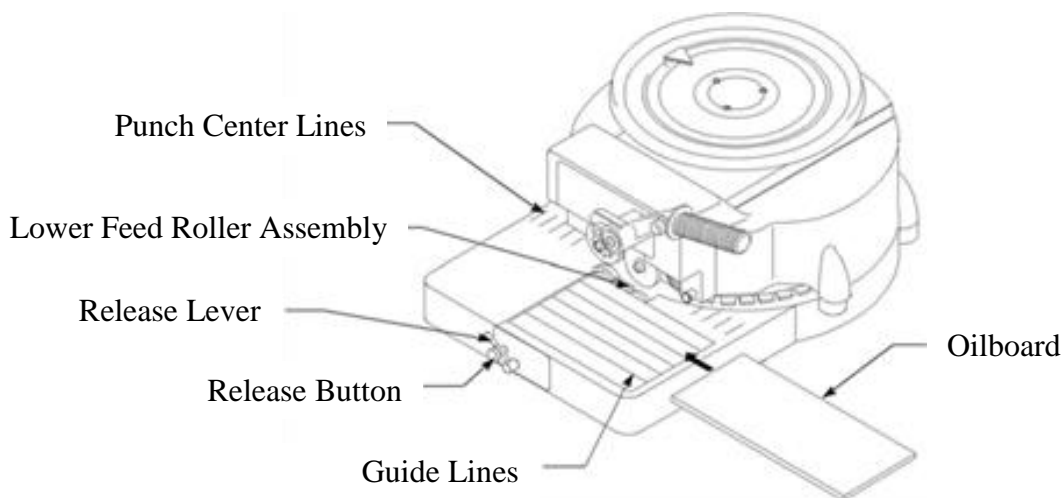

# Operation

---

## Cutting the Oilboard

To cut and space characters follow the steps below and refer to Figure C.

1. Move the hand wheel and align the indicator with the desired character.
2. When the indicator is aligned, push the handle down.
3. To create a space between words, press the word space button on the handle as you push down. See Figure C.
4. When a line of stenciling is complete, swing the release lever to the right to release the lower feed rollers.
5. Align the oilboard in the starting position. Advance the top of the oilboard into the machine and align the bottom of the oilboard with an appropriate guide line.

**Figure C**

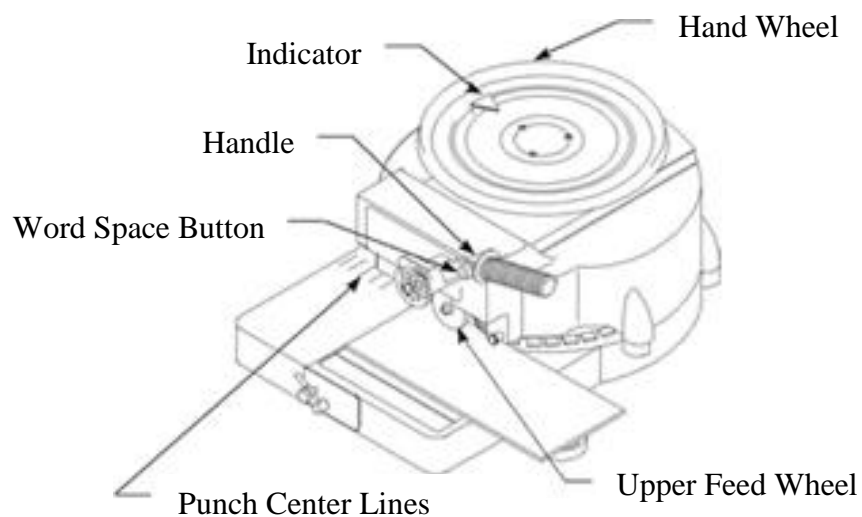

# Maintenance

---

## Cleaning the Punches

As you use your stencil machine, the punches may become clogged with oilboard particles. If these particles prevent the machine from cutting complete characters, the punches need to be cleaned. Follow the step below and refer to Figure D to clean the punches

*Note: Only clean a punch when the machine is not cutting properly. The lubricants in the oilboard also lubricate the punch and die.*

1. Use the wire cleaning hook that is included with the stencil machine to dislodge the paper particles stuck in the raised characters of the punches. The punch is the upper part of the character set and can be reached easily by guiding the hook under the hood casting and scraping the punch. The lower part is the die and does not require cleaning because the punchings fall through the opening in the die.

**Figure D**

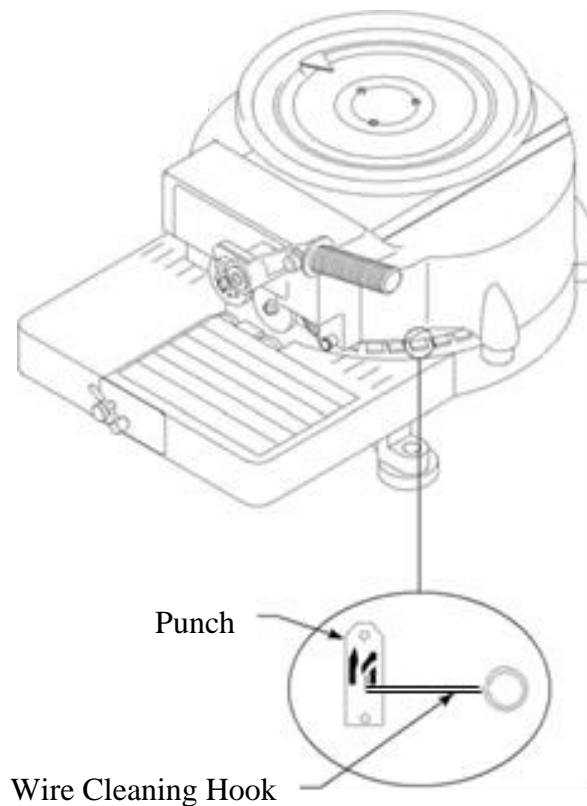

# Maintenance

---

## Oiling the Machine

The moving parts under the cover plate, the hood casting, and the base plate should be cleaned and greased with a light oil every one to two years. Marsh Shipping Supply Company, LLC suggests using Dow Corning 1292 Long Life Bearing Grease. To clean and grease the parts under the cover plate, refer to the following steps and Figure E.

1. Loosen the five screws on the cover plate.
2. Remove the handle screw and washer and pull the cover plate and handle assembly away from the machine and place it to the side.
3. Oil the moving parts under the cover plate.
4. Replace the cover plate and handle assembly by replacing the five screws on the cover plate, the washer and handle screw.

**Figure E**

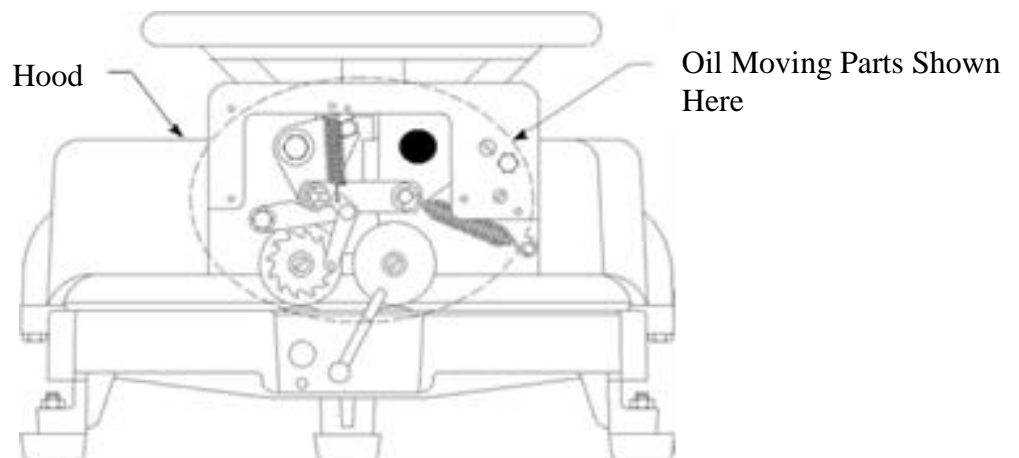

# Troubleshooting

---

This troubleshooting section describes potential problems that you may encounter while working with your hand stencil machine, outlines the possible causes for these problems, and guides you through the corrective actions. Follow the procedures outlined in the Operation and Maintenance sections of this manual to help prevent problems from occurring. For further assistance, please contact your Marsh distributor, or Marsh Shipping Supply Company, LLC at:

## Technical Support

Email: [tech@msscllc.com](mailto:tech@msscllc.com)

**Problem:**     **The oilboard is moving unevenly through the machine causing the characters to be slanted or crooked.**

*Possible Cause:*

1. The tracking needs to be adjusted.

*Solution:*

1. Adjust the tracking on the lower feed roller assembly. See page 12.

**Problem:**     **The spacing between the characters is uneven.**

*Possible Cause:*

1. A buildup of dirt and/or heavy oil on the left feed wheel may be causing the oilboard to slip while moving through the machine, thus causing erratic spacing of the characters.
2. The tension of the stud collar on the eccentric shaft can also affect the spacing if the tension is too tight or too loose.

*Solution:*

1. Clean the treads on the left feed wheel with a wire brush. See page 11.
2. Be sure the tension of the stud collar is set correctly by following steps 1 through 6 on page 15 and 7 through 10 on page 16.

## Troubleshooting

---

**Problem:** The oilboard is moving erratically through the machine.

*Possible Cause:*

*Solution*

- |  |   |
|--|---|
| 1. The punches are clogged with oilboard particles.  | 1. Clean the punches with the cleaning hook. See page 7.  |
| 2. The punch depth adjustment may need to be increased.  | 2. The punch depth adjustment is preset at the factory. Only adjust the punch depth if the punches are not cutting properly after being cleaned with the cleaning hook. To adjust the punch depth, see page 13. |
| 3. If cleaning the punches with the cleaning hook and adjusting the punch depth does not improve the cutting of the characters. The punch and die need to be replaced. | 3. Replace the punch and die that is not cutting properly. See page 14.   |
| 4. There is a buildup of heavy oil on the moving parts under the cover plate.  | 4. Be sure the machine is properly oiled and cleaned every one to two years. See page 8 for information on oiling the parts under the cover plate.  |
| 5. The treads on the left feed wheel are dirty.  | 5. Clean the treads on the left feed wheel with a wire brush. See page 11.  |

**Problem:** The lower feed rollers are not gripping the oilboard.

*Possible Cause:*

*Solution:*

- |   |   |
|---|---|
| 1. The left lower feed roller is catching or not moving smoothly because of wear. | 1. Replace the lower feed roller assembly. See page 15. |
|---|---|

# Repair

---

This section provides steps that guide you through the repair or replacement of certain parts.

## Cleaning the Threads on the Left Feed Wheel

1. Loosen the bolt on the left feed wheel.
2. Carefully push the spacing cam to the right and remove the left feed wheel. See Figure F.

*Note: please observe the placement of the washers on the back of the feed wheel because they must be put back in the correct order.*

3. Brush the threads of the feed wheel with a wire brush to remove dirt and particles.
4. Put the washers into place on the back of the feed wheel. The smaller washer is placed directly on the back of the feed wheel and the larger spring washer sits over it with the flat side resting on the feed wheel. The third washer follows the spring washer. See Figure F. The 1" (25.4 mm) machines, have a fourth washer behind the third one.
5. Push the spacing cam to the right and put the feed wheel in place.
6. Tighten the bolt to secure the wheel.

**Figure F**

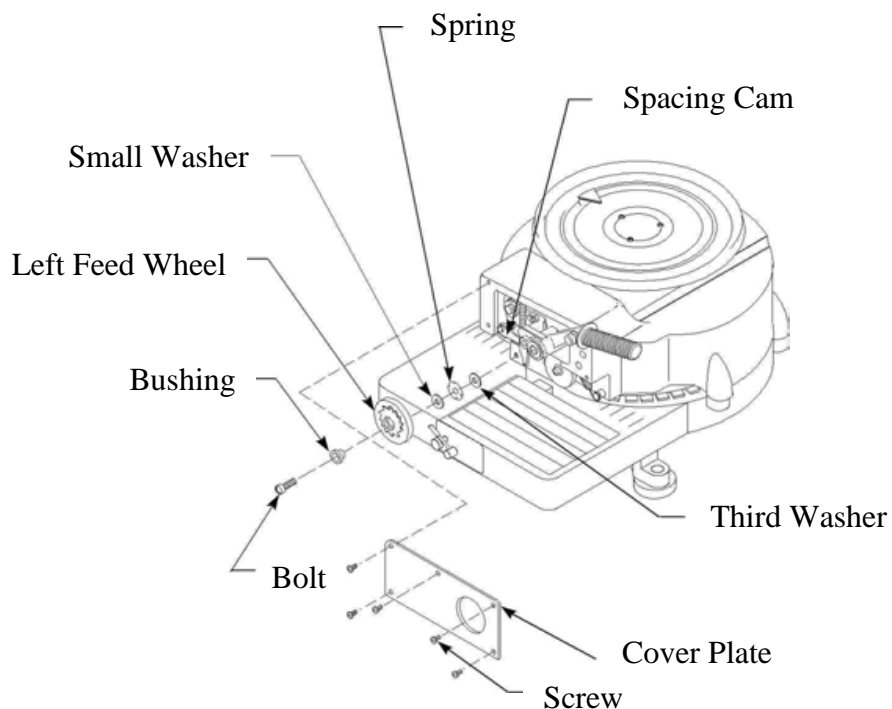

# Repair

---

## Adjusting the Tracking on the Lower Feed Roller Assembly

1. Turn the machine upside down.
2. To raise the feeding of the oilboard above a guide line, turn the inside nut clockwise. See Figure G.
3. To lower the feeding of the oilboard below a guide line, turn the outside nut counterclockwise. See Figure G.
4. Tighten the opposite nut after making the adjustment, but be careful not to over-tighten it.
5. Feed the oilboard through the machine after each adjustment to test the setting of the nuts.

**Figure G**

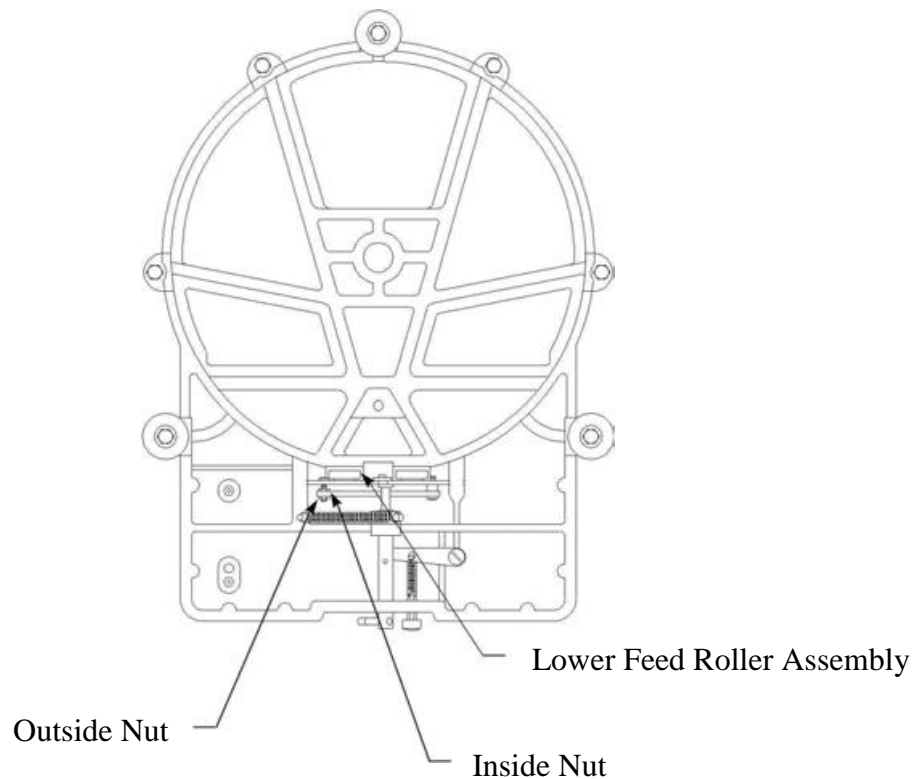

# Repair

---

## Adjusting the Punch Depth

1. Loosen the five screws on the front cover plate.
2. Remove the handle screw and washer and pull the cover plate and handle assembly away from the machine and place it to the side.
3. Loosen the nut shown in Figure H by turning it clockwise.
4. Adjust the square head screw to the desired position. Only turn the square head screw  $\frac{1}{4}$  turn at a time. If you want to apply more punch depth, turn the square head screw clockwise to move it up. If you want to apply less punch depth, turn the square head screw counterclockwise to move it down.
5. After the adjustment is made tighten the nut to secure the position of the square head screw.
6. Replace the cover plate and handle assembly by tightening the five cover plate screws, the washer and handle screw.
7. Test the setting of the punch depth after each adjustment by cutting a piece of oilboard.

**Figure H**

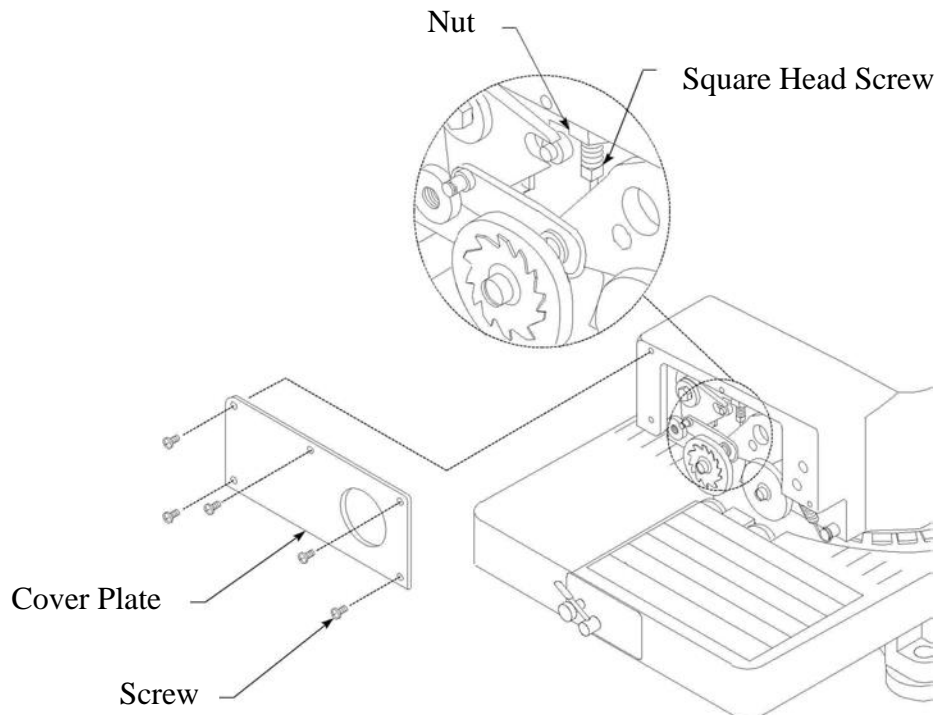

# Repair

---

## Replacing a Punch and Die

1. Turn the machine upside down.
2. Locate the punch and die that needs to be replaced.
3. Loosen the two screws in the die and remove it. See Figure I.
4. Insert the screw driver through the holes in the die carrier and loosen the two screws in the punch and remove it.
5. Position the new punch with its rounded edge facing the outside of the machine.
6. Replace the two screws on the punch.
7. Carefully position the die on the cut out portion of the punch. The die rests on the punch with its wide edge facing the outside of the machine.
8. Lift the punch and dies up against the carrier and hold the punch and die while you replace and tighten the two screws in the die. Tighten each screw a bit at a time to equalize the strain on the die.
9. Separate the punch from the die by tapping the punch lightly.
10. Cut a few characters to test the new punch and die.

**Figure I**

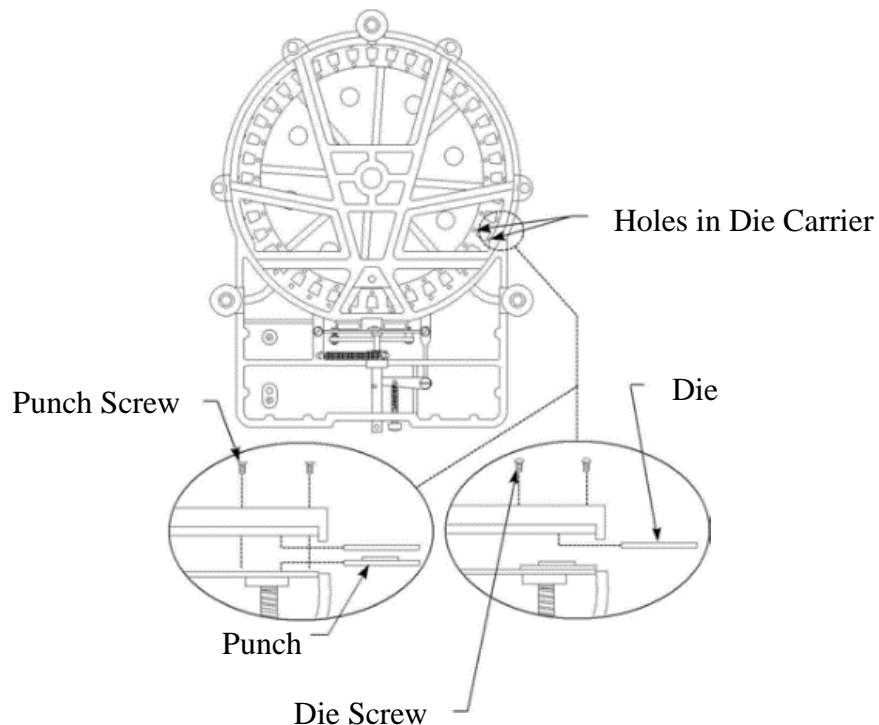

# Repair

---

## Replacing the Lower Feed Roller Assembly

1. Turn the machine upside down.
2. Press the release button to unlock the lever. See Figure J.
3. Note the position of the set screw for proper reassembly and then loosen the set screw on the stud collar using an allen wrench.
4. Pull the eccentric shaft toward you, removing it from the hole in the feed roller assembly.
5. Remove the feed roller assembly and place the new one in position.
6. Push the eccentric shaft back into position so that it is seated in the hole of the feed roller assembly.

**Figure J**

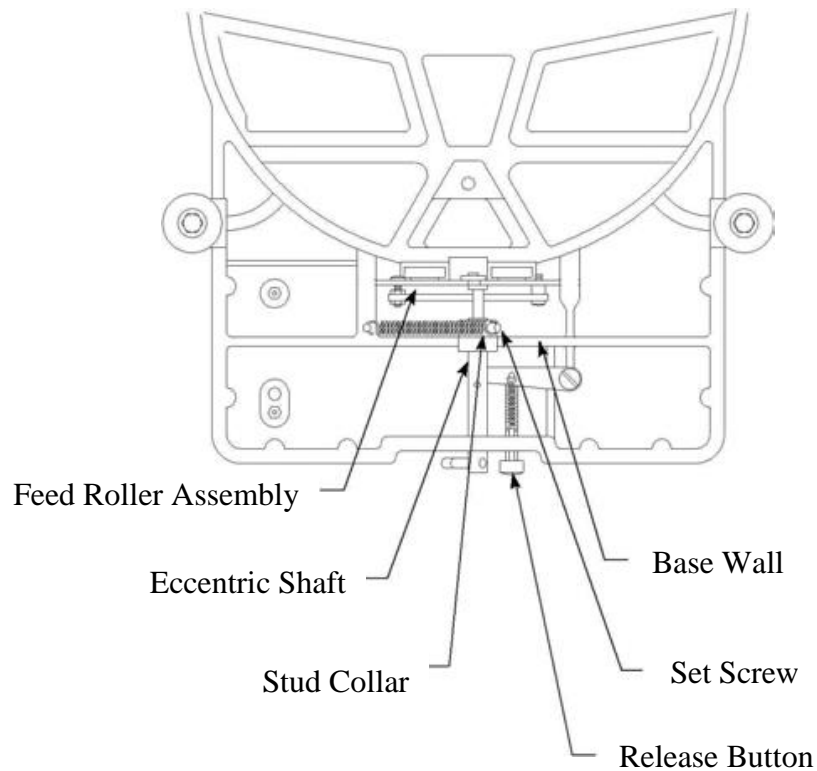

## Repair

---

7. Place the stud collar about 1/16" (1.6 mm) from the base wall, but not so close that it rubs against the wall.
8. Insert the allen wrench in the set screw of the stud collar and pull the stud collar and spring to the right. Make sure the eccentric shaft remains inserted in the hole of the feed roller assembly and the collar is flush with the base wall closest to you.
9. When these parts are in position and the tension on the spring is as it is shown in Figure J, tighten the set screw to its original position.
10. Test the play of the eccentric shaft and stud collar by gently pulling on the stud collar. Some movement should be allowed.

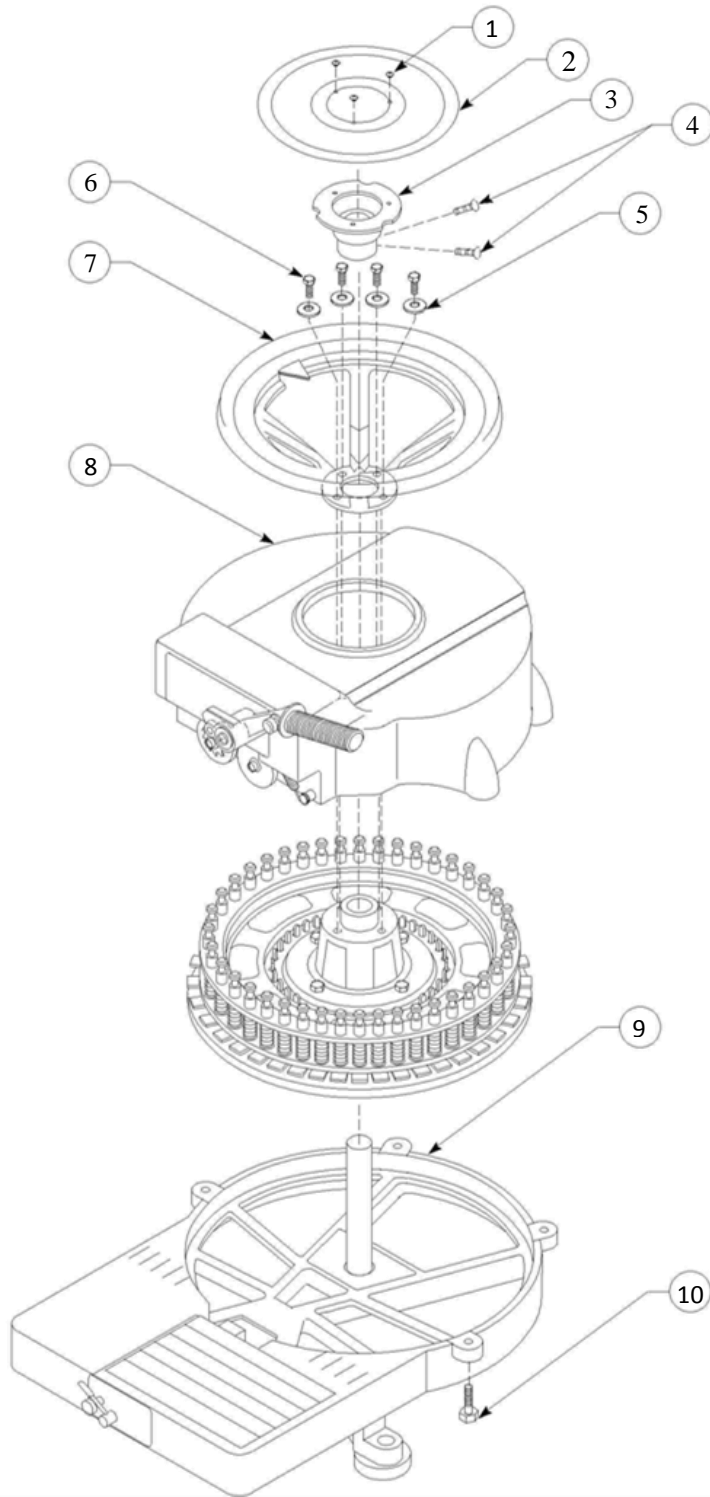

[Link to Parts List pg. 21](#)

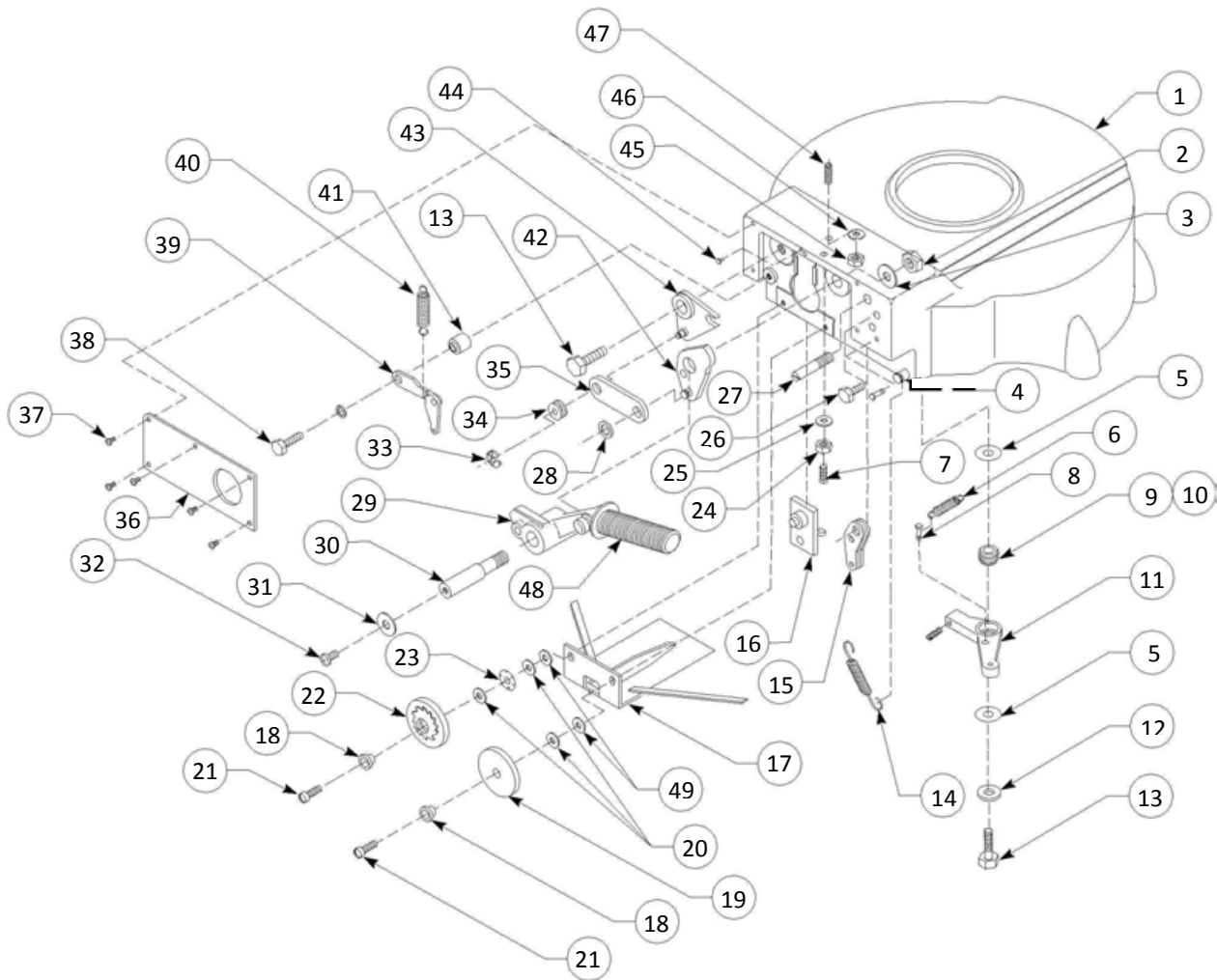

[Link to Parts List pg. 21](#)

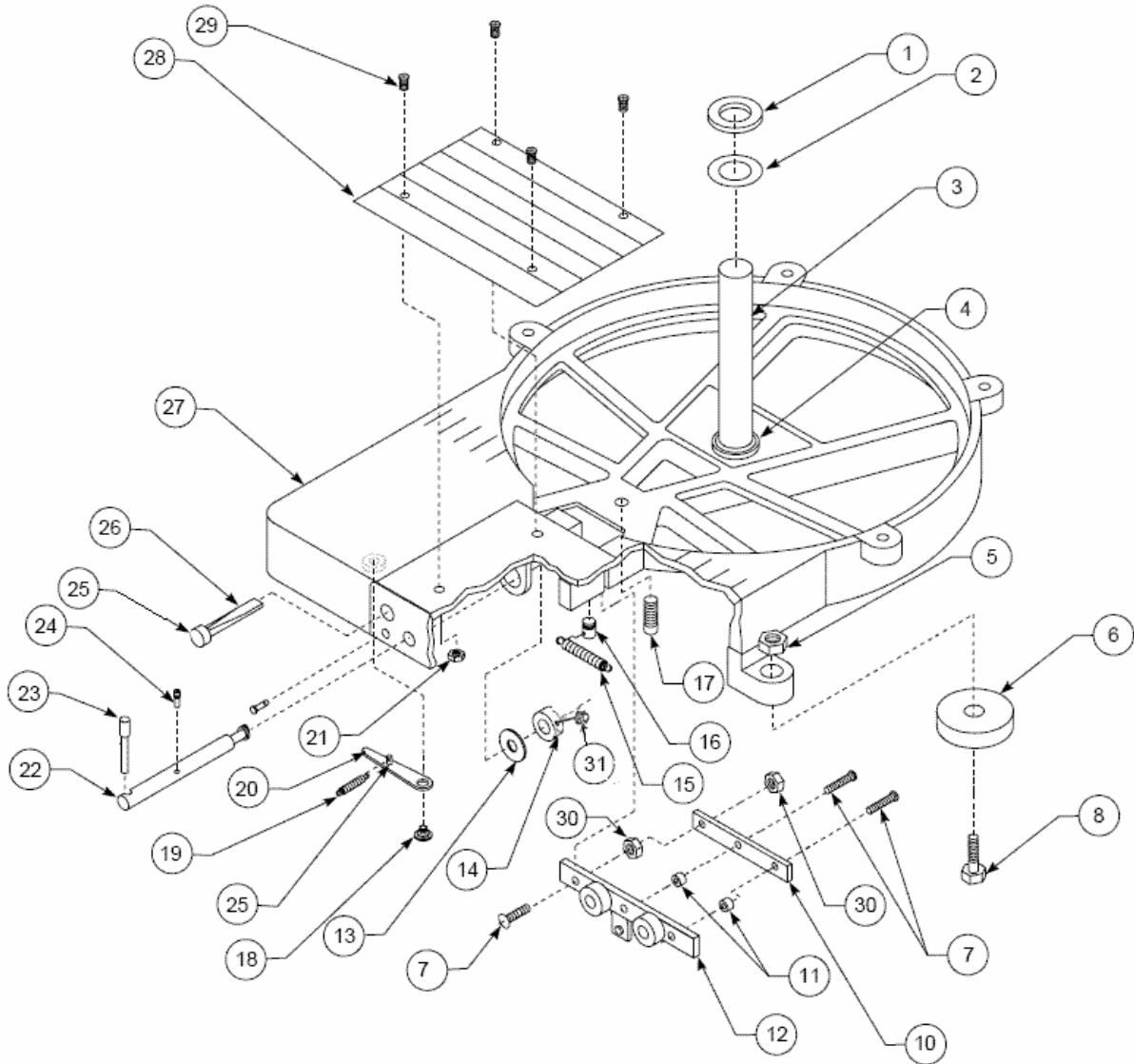

[Link to Parts List pg. 23](#)

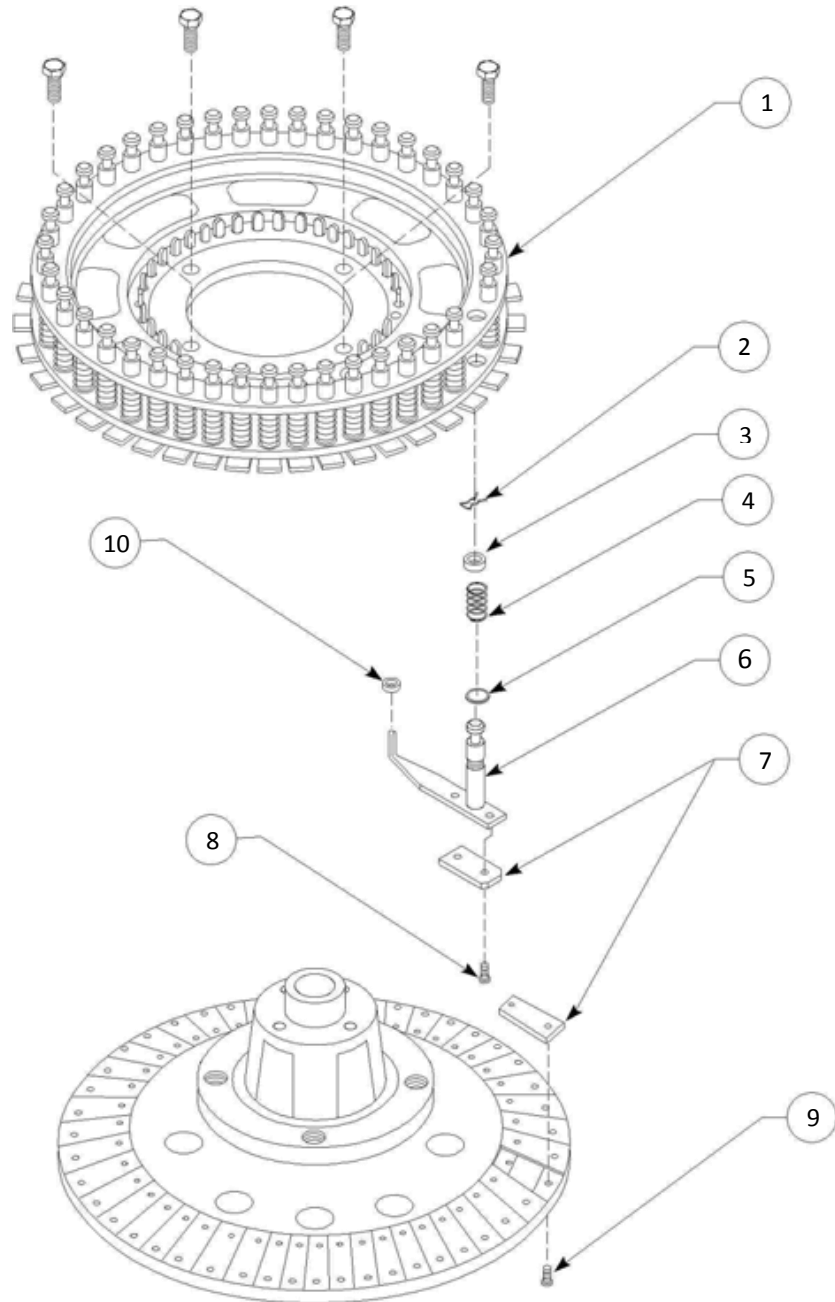

[Link to Parts List pg. 24](#)

## Parts List

---

The following pages show the Hand Stencil Machine and the corresponding numbers for repair parts. Please order your replacement parts by requesting the part number shown. Please also note the quantity provided in each package and the specific part number necessary for your machine.

### Stencil Machine Assembly, see page 17

	<b>Description</b>	<b>Part Number</b>	<b>Quantity per kit</b>
1.	Screw, Phillips truss head	RP32A	5
2.	Dial blank, manual	RP32	1
3.	Holder, dial	RP08	1
4.	Screw, set square head	RP08B	5
5.	Washer	RP1503C	5
6.	Screw, cap head hex	RP04A	5
7.	Wheel assy,hand	RP07X	1
8.	Hood (1/4", 1/2", 3/4")	RP02-SHQ	1
	Hood (1")	RP02-R	1
9.	Base, with shaft and plate (1/2")	RP01X-H	1
	Base, with shaft and plate (3/4")	RP01X-S	1
	Base, with center shaft 1"	RP01X-R	1
	Base, with shaft and plate 1/4"	RP01X-Q	1
10.	Cap, hex head (1/4", 1/2", 3/4")	RP01A-SHQ	5
	Cap, hex head (1")	RP01A-R	5

### Front Assembly, see page 18

	<b>Description</b>	<b>Part Number</b>	<b>Quantity per kit</b>
1.	Hood (1/4", 1/2", 3/4")	RP02-SHQ	1
	Hood (1")	RP02-R	1
2.	Nut, hex	RP22A	5
3.	Washer, lock internal tooth	RP22B	5
4.	Stud, spring	RP37	1
5.	Washer	RP35SW	5
6.	Spring, centering arm	RP30S	2
7.	Screw, set square head	RP47	5
8.	Pin, release button	RP18B	1
9.	Arm liner, assy centering	RP35A	1
10.	O-ring	RP35B	5
11.	Arm assy, centering (1/4", 1/2", 3/4")	RP30X-SHQ	1
	Arm assy, centering (1")	RP30X-R	1
12.	Washer	RP35W	5
13.	Screw, cap hex head	RP09A	5
14.	Spring, handle	RP37S	1
15.	Rocker assy, centering	RP28	1
16.	Plunger assy	RP31	1

## Parts List

---

**Front Assembly**  
**see page 18**  
**(continued)**

	<b>Description</b>	<b>Part Number</b>	<b>Quantity per kit</b>
17.	Stripper assy (1/4", 1/2", 3/4", 1")	RP33	1
18.	Bushing, feed wheel	RP23A	4
19.	Wheel, feed right	RP23R	5
20.	Washer, feed wheel	RP23W	5
21.	Screw, slot flat head	RP38	5
22.	Wheel assy, feed left (1/4")	RP23LB-Q	1
	Wheel assy, feed left (1/2")	RP23LB-H	1
	Wheel assy, feed left (3/4")	RP23LB-S	1
	Wheel assy, feed left (1")	RP23LB-R	1
23.	Washer, sprag spring	RP1611-AR	5
24.	Nut	RP47A	1
25.	Washer, lock integral tooth	RP47B	1
26.	Stop, spacing	RP44	2
27.	Stud, centering rocker	RP29	1
28.	Washer, link pin right	RP13A	5
29.	Handle, assy operating (1/4", 1/2", 3/4", 1")	RP20X	1
30.	Shaft, handle	RP22	1
31.	Washer	RP21	5
32.	Screw, phillips pan head	RP06C-R	5
33.	Ring, lock	RP3157	5
34.	Follower, spacing cam	RP24	2
35.	Link (1/4", 1/2", 3/4")	RP12-SHQ	1
	Link (1" machine)	RP12-R	1
36.	Cover plate, front	RP43	1
37.	Screw, phillips pan head	RP43A	5
38.	Screw, cap hex head	RP36B	5
39.	Cam assy, spacing (1/4")	RP25-Q	1
	Cam assy, spacing (1/2")	RP25-H	1
	Cam assy, spacing (1/4")	RP25-S	1
	Cam assy, spacing (1/4")	RP25-R	1
40.	Spring, spacing finger	RP25S	2
41.	Bushing, spacing cam	RP36	2
42.	Cam assy, centering	RP10	1
43.	Rocker assy	RP14	1
44.	Stud, spring spacing	RP25E	5
45.	Nut, hex jam	RP47A	5
46.	Washer, lock integral tooth	RP47B	5
47.	Screw, set (1/4", 1/2", 3/4")	RP48-SHQ	5
	Screw, set (1")	RP48-R	5
48.	Grip, Handle 7/8" Flangeless	RP27944	1
49.	Washer	RPTC19	5

## Parts List

---

**Base Assembly,  
see page 19**

	<b>Description</b>	<b>Part Number</b>	<b>Quantity per kit</b>
1.	Washer	RP19W2	5
2.	Washer	RP19W1	5
3.	Shaft, center (1/4", 1/2", 3/4")	RP33101	1
4.	Wick, center shaft oil	RP19A	5
5.	Nut	RP51N	5
6.	Foot, rubber	RP77	1
7.	Screw, socket head 10-32x3/4 Grade 5	RP15GH	5
8.	Screw, cap hex head	RP1503B	5
9.	Screw, round head slotted	RP15G	5
10.	Bar, adjustment	RP15C	1
11.	Spacer	RP15D	5
12.	Roller assy, lower feed	RP15	1
13.	Washer	RP16W	5
14.	Collar, spring stud	RP16E	5
15.	Spring, lower feed roll	RP16S	2
16.	Stud, spring	RP16D	2
17.	Screw, set socket flat	RP42	5
18.	Screw, stop pawl	RP18A	1
19.	Spring, release button	RP17S	2
20.	Pawl	RP18	1
21.	Nut, hex jam	RP01D-SHQ	5
22.	Shaft assy, eccentric (1/4", 1/2", 3/4")	RP16-SHQ	1
	Shaft assy, eccentric (1")	RP16-R	1
23.	Cap, eccentric shaft handle	RP16G	5
24.	Eccentric shaft stop pin	RP16A	2
25.	Release button pin	RP18B	1
26.	Button, release shaft	RP17	1
27.	Base, with shaft and plate (1/4")	RP01X-Q	1
	Base, with shaft and plate (1/2")	RP01X-H	1
	Base, with shaft and plate (3/4")	RP01X-S	1
	Base, with shaft and plate (1")	RP01X-R	1
28.	Plate, table (1/4")	RP01PL-Q	1
	Plate, table (1/2")	RP01PL-H	1
	Plate, table (3/4")	RP01PL-S	1
		RPJ500-0011-	
29.	Screw, phillips flat head (1/4", 1/2", 3/4")	008	5
30.	Nut, hex jam	RP15N	5
31.	Screw, set cam grip	RP1110A	5

## Parts List

---

Carriage Assembly,  
see page 20

Description	Part Number	Quantity per kit
1. Carrier, punch (1/4", 1/2", 3/4")	RP04-SHQ	1
Carrier, punch (1")	RP04-R	1
2. Retainer, Spring	RP27	5
3. Washer, felt (1/4", 1/2", 3/4")	RP78-SHQ	5
Washer, felt (1")	RP78-R	5
4. Spring, punch (1/4", 1/2", 3/4")	RP26S-SHQ	5
Spring, punch (1")	RP26S-R	5
5. Holder, punch and shank assy (1/4", 1/2", 3/4")	RP05X-SHQ	1
Holder, punch and shank assy (1")	RP05X-R	1
6. Washer, rubber (1/4", 1/2", 3/4")	RP26W-SHQ	5
Washer, rubber (1")	RP26W-R	5
7. Punch and die - set of 40 1/4" characters	RPQ5DP	1
Punch and die - set of 40 1/2" characters	RPH5DP	1
Punch and die - set of 40 3/4" characters	RPS5DP	1
Punch and die - set of 40 1" characters	RPR5DP	1
8. Screw, punch (1/4", 1/2", 3/4")	RP06B-SHQ	5
Screw, punch (1")	RP06B-R	5
9. Screw, die (1/4", 1/2", 3/4")	RP06C-SHQ	5
Screw, die (1")	RP06C-R	5
10. Washer, felt	RP79	5
11. Carrier, Die (1/4", 1/2", 3/4")	RP03-SHQ	1
Carrier, Die (1")	RP03-R	1

