

\* KEYBOARD OVERLAY

SERIAL #	PART #
1 - 1999	PS2A-102
2000 & ABOVE	PS2A-102-CE

\* KEYBOARD-LOWER BOARD

SERIAL #	PART #
1 - 1999	PS2A-103
2000 & ABOVE	PS2A-103-CE

**ITEM 1 - COVER ASSY W/ KEYBOARD**

\*

SERIAL #	PART #
1 - 1999	PS2A-109-A
2000 & ABOVE	PS2A-109-CE

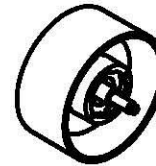

**ITEM 2 - REEL UNIT  
PS2A-107**

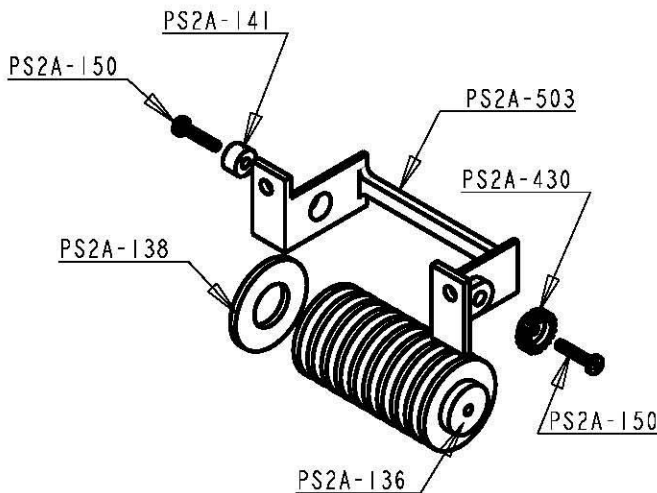

**ITEM 3 - ASSY. SEPARATING ROLLER HOLDER  
PS2A-533 - ONLY SOLD AS COMPLETE ASSEMBLY**



**ITEM 4 - PRESS ROLLER COLLAR  
PS2A-155**

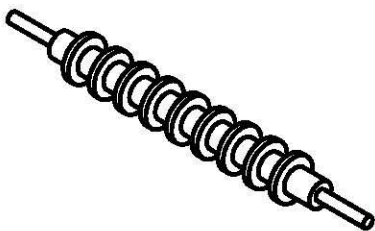

**ITEM 5 - PRESS ROLLER  
PS2A-154**

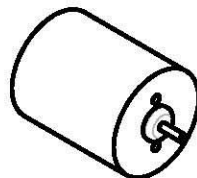

**ITEM 6 - FEED MOTOR  
PS2A-435**



**ITEM 7 - PINION GEAR UNIT 2  
PS2A-528**

**PS2A ITEM LIST**



Shelton, CT 06484

\* CE version PS2A uses parts not compatible with previous version. Select part number based on serial number printed on product ID label

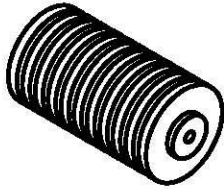

**ITEM 8 - FEED ROLLER 2**  
**PS2A-312**

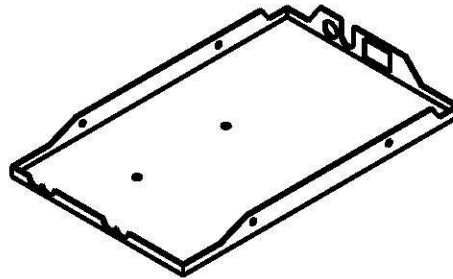

**ITEM 9 - BASE PLATE**  
**PS2A-115**

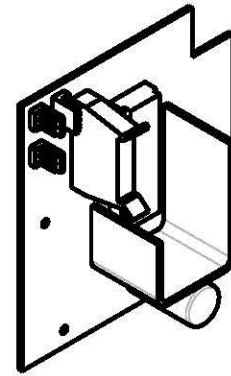

\* **ITEM 10 - PCB ASSEMBLY**

SERIAL #	PART #
1-1999	PS2A-505
2000 & ABOVE	PS2A-505-CE

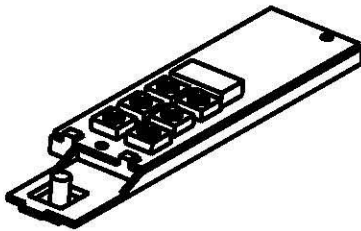

\* **ITEM 11 - DISPLAY BOARD**

SERIAL #	PART #
1-1999	PS2A-506
2000 & ABOVE	PS2A-506-CE



**ITEM 12 - FEED ROLLER GEAR 3**  
**PS2A-427**

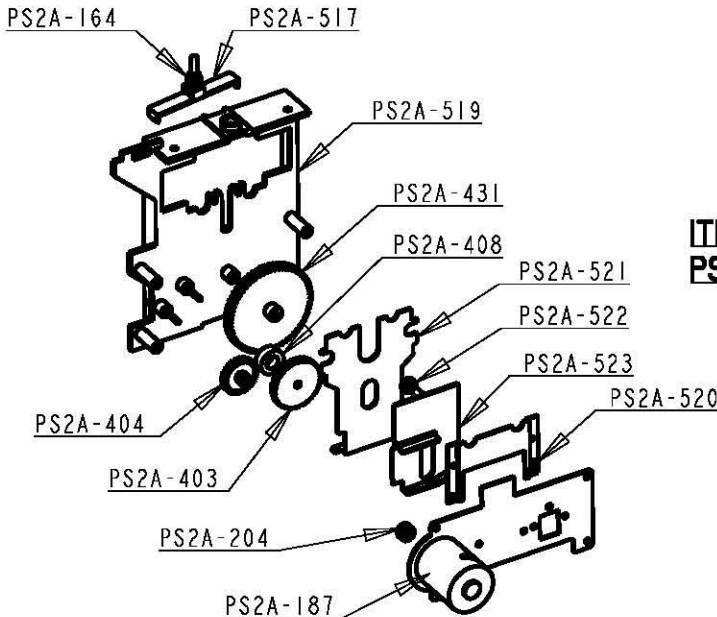

**ITEM 13 - ASSY, FRONT HOLDER**  
**PS2A-518 - ONLY SOLD AS COMPLETE ASSEMBLY**



**ITEM 14 - CONTROL KNOB**  
**PS2A-106**

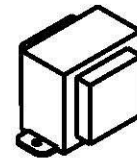

**ITEM 15 - TRANSFORMER**  
**PS2A-111 (110v)**  
**PS2A-112 (220v-240v)**

\* CE version PS2A uses parts not compatible with previous version. Select part number based on serial number printed on product ID label



**PS2A ITEM LIST**  
**Better Packages, Inc.®**

Shelton, CT 06484

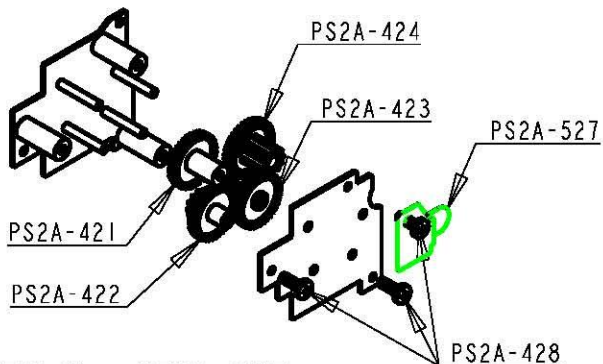

**ITEM 16 - GEAR UNIT**  
**PS2A-418 - ONLY SOLD AS COMPLETE ASSEMBLY**

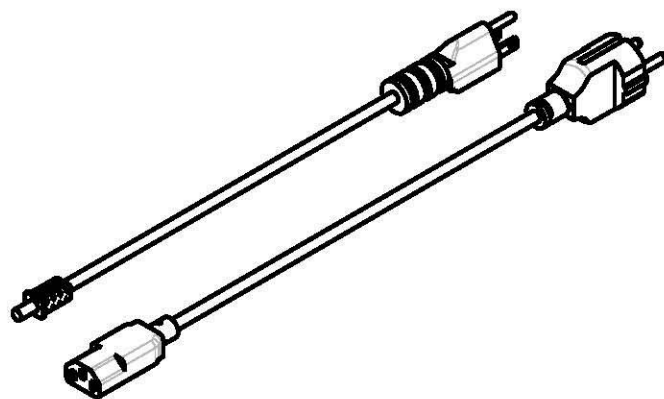

**ITEM 17 - POWER CORD WITH PLUG**  
**PS2A-205-US (110v)**  
**PS2A-205-CE (220v-240v)**

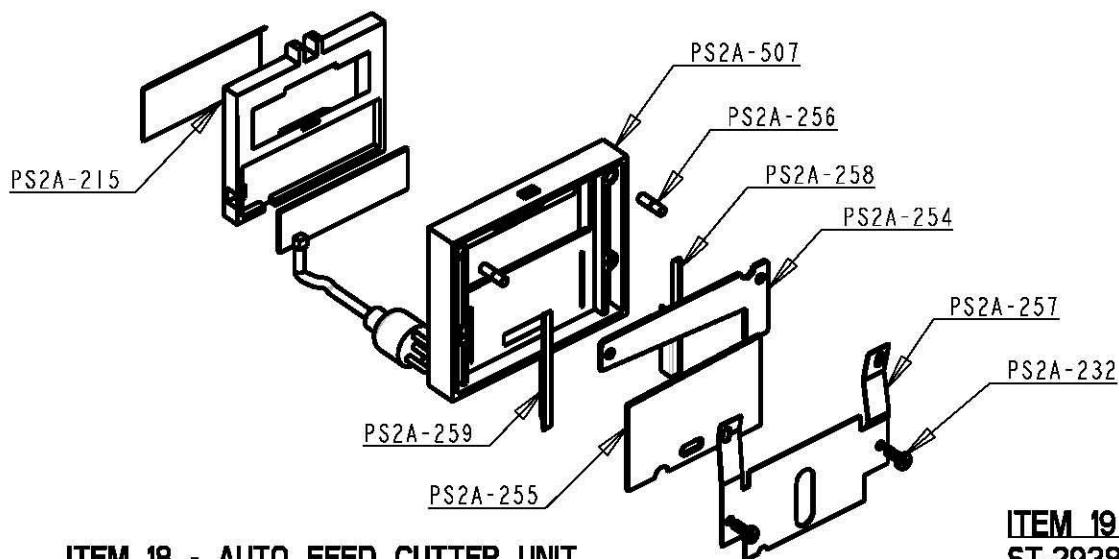

**ITEM 18 - AUTO FEED CUTTER UNIT**  
**PS2A-550 - ONLY SOLD AS COMPLETE ASSEMBLY**

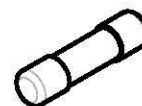

**ITEM 19 - FUSE**  
**ST-2938 5x20mm 1.5A (110v)**  
**ST-2943 5x20mm 1A (220v-240v)**

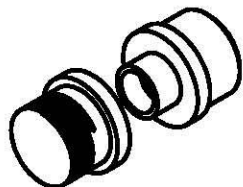

**ITEM 20 - FUSE HOLDER**  
**PS2A-121**

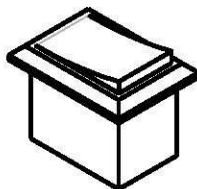

**ITEM 21 - POWER SWITCH**  
**PS2A-118**

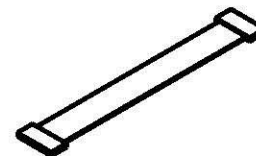

**ITEM 22 - CONNECTOR**

SERIAL #	PART #
1-1999	PS2A-509
2000 & ABOVE	PS2A-509-CE